

1 CRTE 4-1 A-P-A-E-AUUE

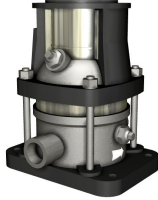

: 98388860

EN 12756

PJE /

1-

PI-

Grundfos

- "Power On":

- « »:

- " ":

R100 (). Grundfos GO

5 , 0 (4) -20 , 0-5 , 0-10 , 0,5 - 3,5

, 0-10 , 0 (4) -20

Pt100/Pt1000

- LiqTec,

- Grundfos

- 24 ()

- GENibus

: -20 .. 120 °C

: 20 °C

: 998.2 / ³

: 3500 /

: 7.4
 : AUUE
 : CE,TR
 - : ISO9906:2012 3B

 :
 :
 : ASTM B 265
 :
 : ASTM B 265
 : NONE

 :
 Maximum ambient temperature: 50 °C
 . : 25 / 120 °C
 : 25 / -20 °C

 : PJE
 : 42,4 mm
 : FT85

 :
 : 71A
 - : IE5
 - P2: 0.37
 : 50 / 60 Hz
 : 1 x 200-240
 : 2.40-2.10 A
 Cos - : 0.96
 : 360-4000 /
 : 84.0%
 (IEC 34-5): IP55
 (IEC 85): F
 : 98190190

 :
 : MEI : 0.7
 : 20

98388860 CRTE 4-1 A-P-A-E-AUUE

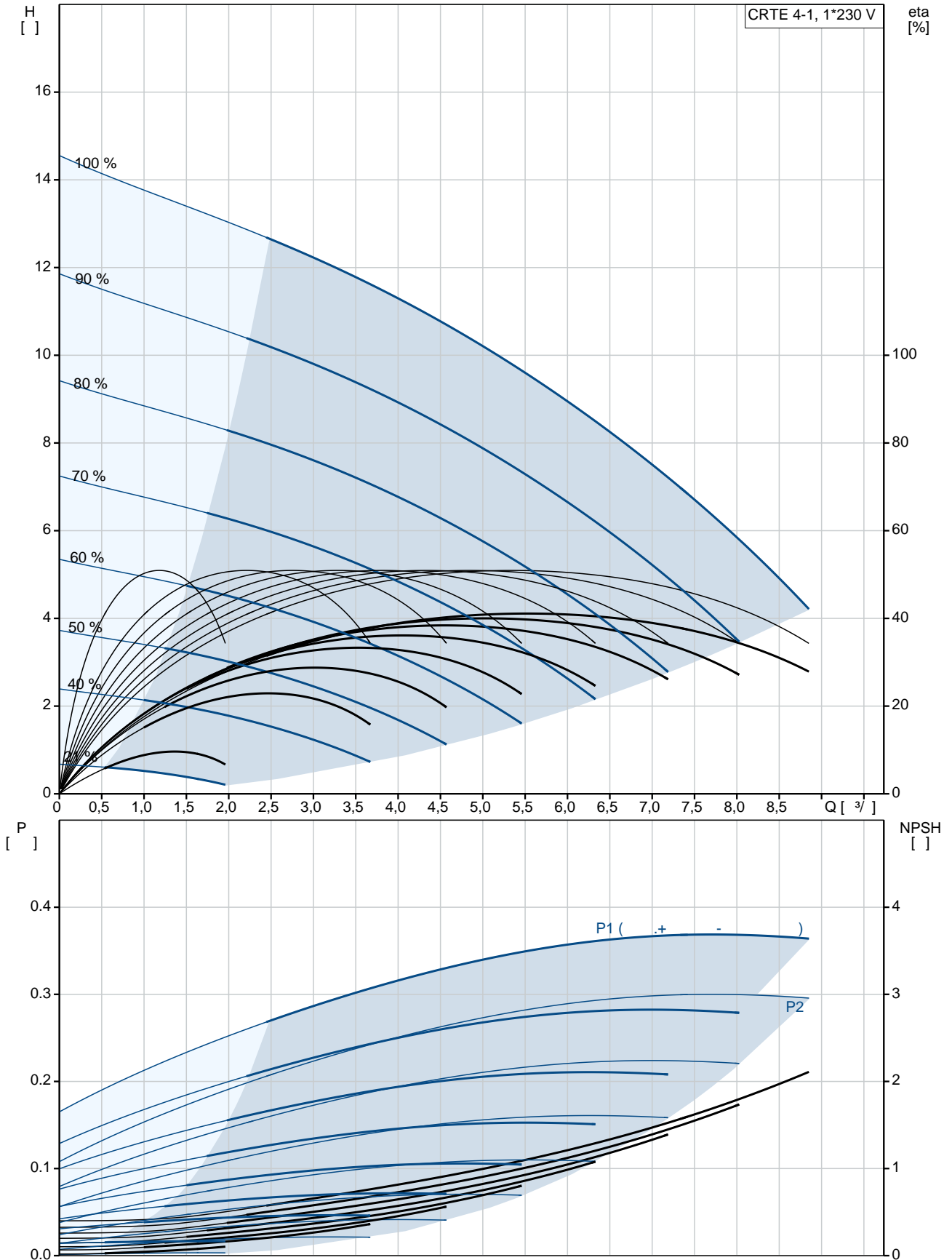

	CRTE 4-1 A-P-A-E-AUUE
	98388860
EAN	5711494167937
	3500 /
Maximum head:	7.4
	14
	14
	2
	1
	AUUE
	CE,TR
	ISO9906:2012 3B
	A
	A
	ASTM B 265
	ASTM B 265
	A
	E
	NONE
Maximum ambient temperature:	50 °C
	25 / 120 °C
	25 / -20 °C
	PJE
	42,4 mm
	FT85
	P
	-20 .. 120 °C
	20 °C
	998.2 / 3
	71A
	IE5
- P2:	0.37
	50 / 60 Hz
	1 x 200-240
	2.40-2.10 A
Cos	0.96
	360-4000 /
	84.0%
(IEC 34-5):	IP55
(IEC 85):	F
	ELEC
	98190190
	HMI200 -

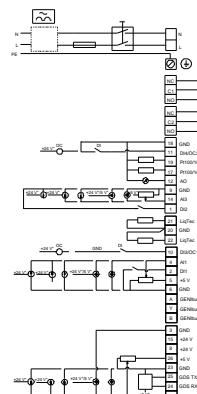
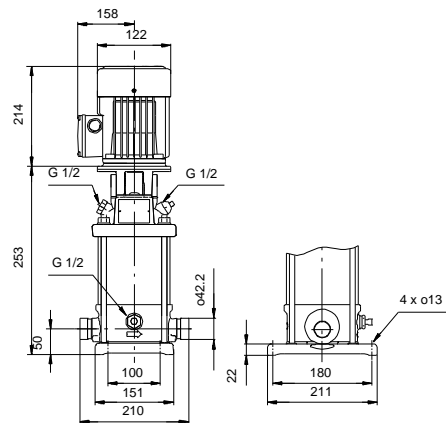
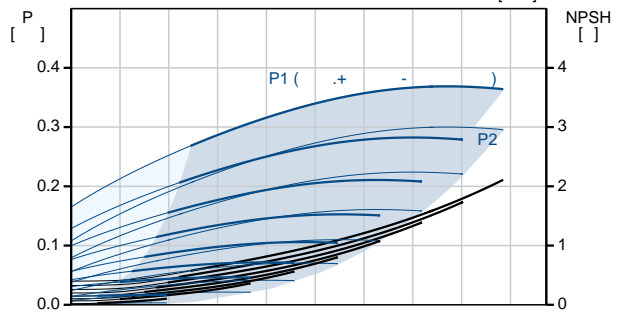
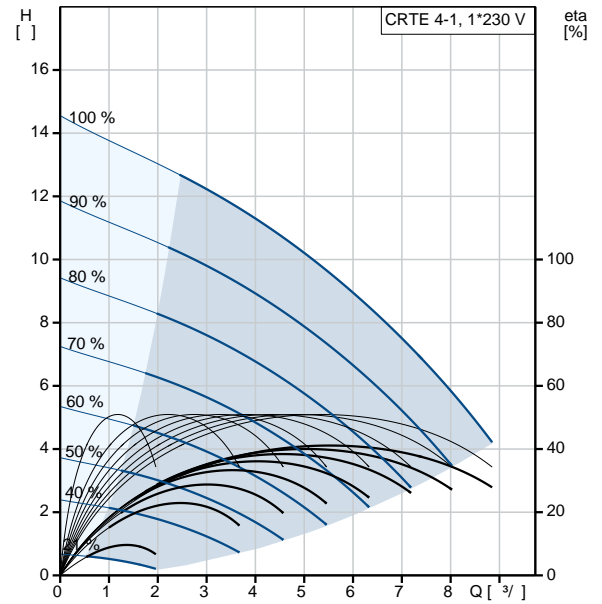

FM300 - Advanced
()

MEI : 0.7

: 20

: 98390420

98388860 CRTE 4-1 A-P-A-E-AUUE

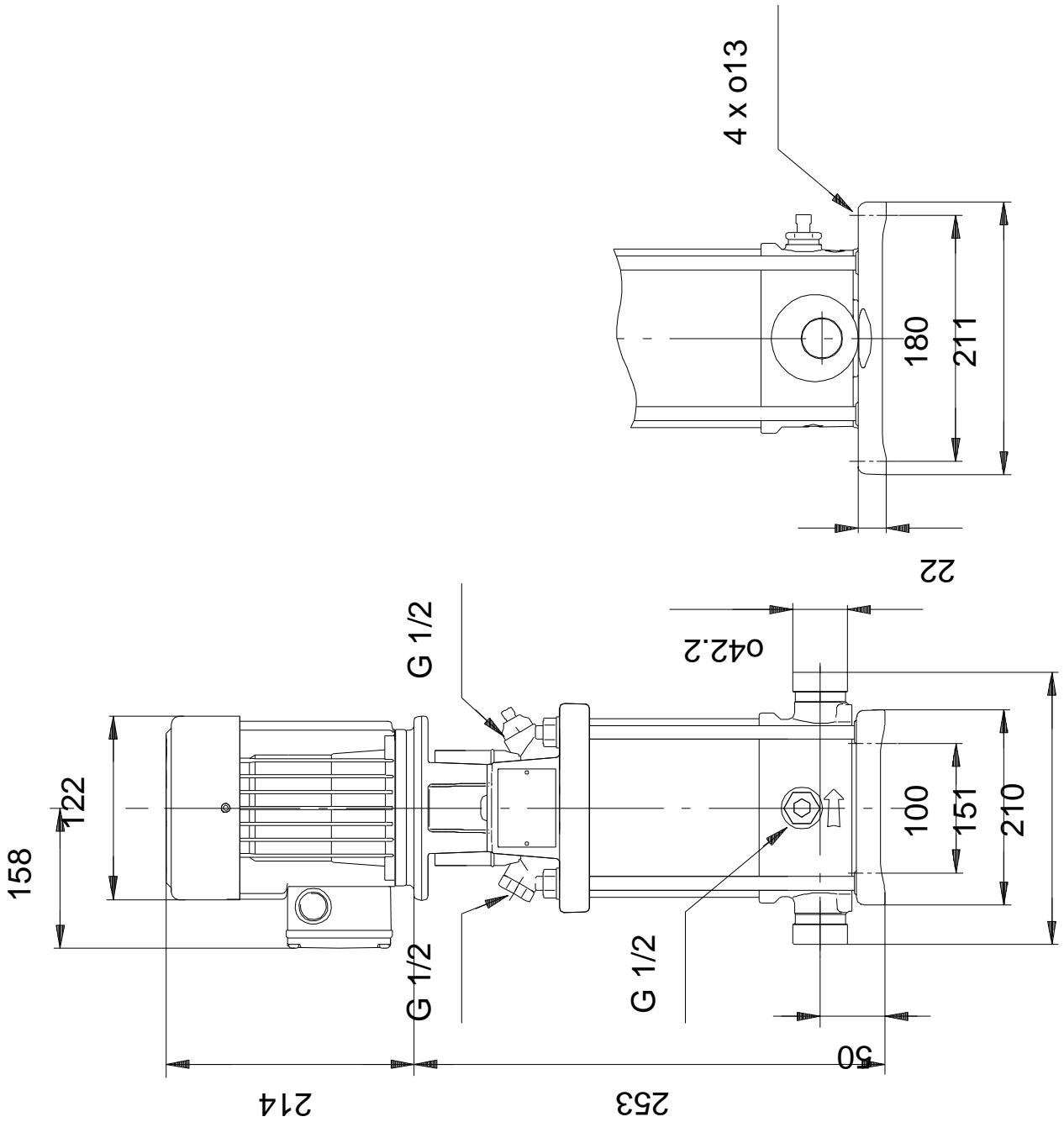

98388860 CRTE 4-1 A-P-A-E-AUUE

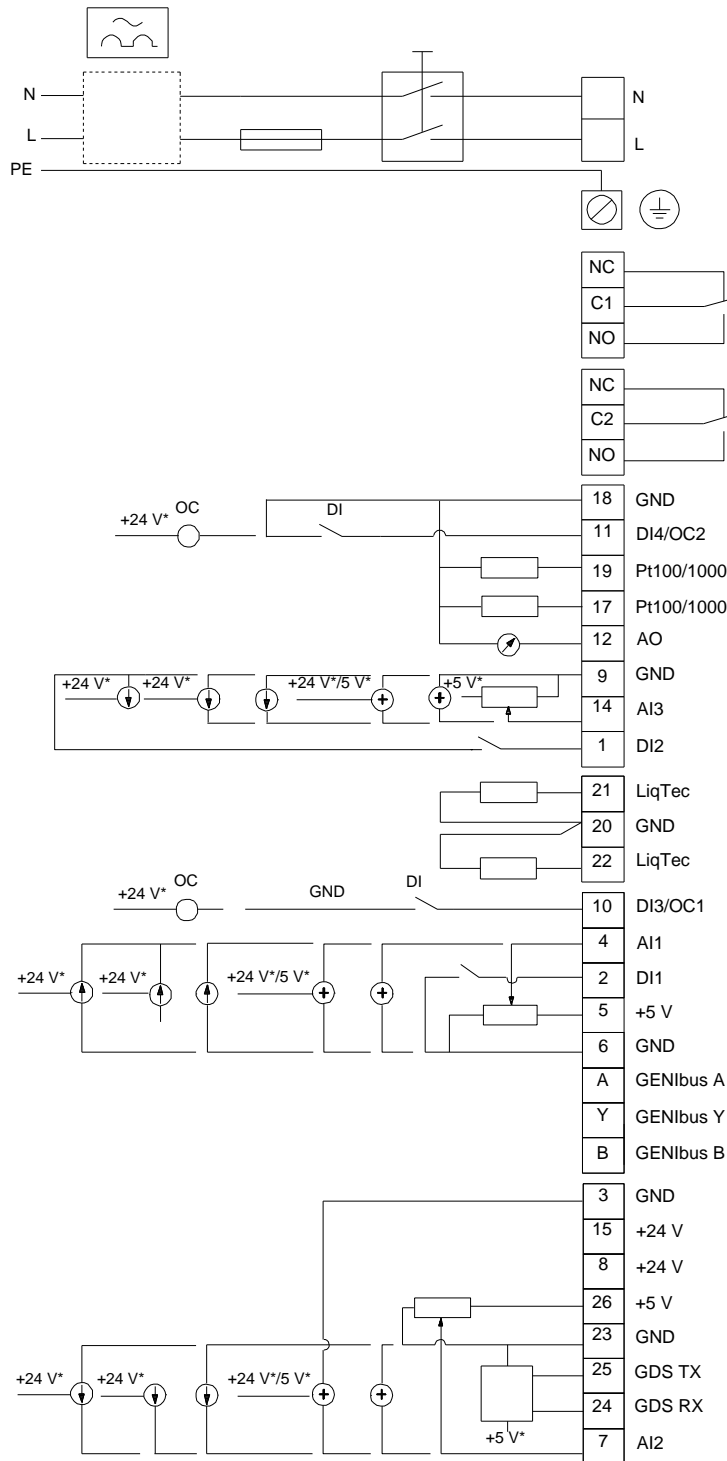

! [], .