

1 CRI 5-10 A-CA-A-E-HQQE



: 96517105

(" - "),

FlexiClamps.

3-

: -20 .. 120 °C  
 : 20 °C  
 : 998.2 / <sup>3</sup>

: 2896 /

: 5.8 <sup>3</sup>/  
 : 51.8

: HQQE  
 : CE, EAC, ACS  
 - : ISO9906:2012 3B

EN 1.4408  
 AISI 316

, EN/DIN: EN 1.4301  
 , AISI/ASTM: AISI 304  
 : SIC

Maximum ambient temperature: 60 °C  
 : 25  
 - : 25 / 120 °C  
 : 25 / -20 °C  
 : FlexiClamp  
 : DN 32  
 : DN 32  
 : PN 25  
 : FT115

: IEC  
 : 90SD

- : IE3  
 - P2: 1.5  
 ( 2), : 1.5  
 : 50 Hz  
 : 3 x 220-240D/380-415Y  
 : 5.70/3.30 A  
 : 750-820 %  
 Cos - : 0.84-0.78  
 : 2890-2910 /  
 : IE3 84,2%  
 : 84.2-84.2 %  
 3/4 : 86.4 %  
 1/2 : 86.0 %  
 : 2  
 (IEC 34-5): 55 Dust/Jetting  
 (IEC 85): F  
 : 85U01906  
 :  
 Frequency converter: .  
 :  
 , MEI : 0.57  
 ( ): 32.1  
 ( ): 36.2  
 : 0.092 <sup>3</sup>

## 96517105 CRI 5-10 A-CA-A-E-HQQE 50

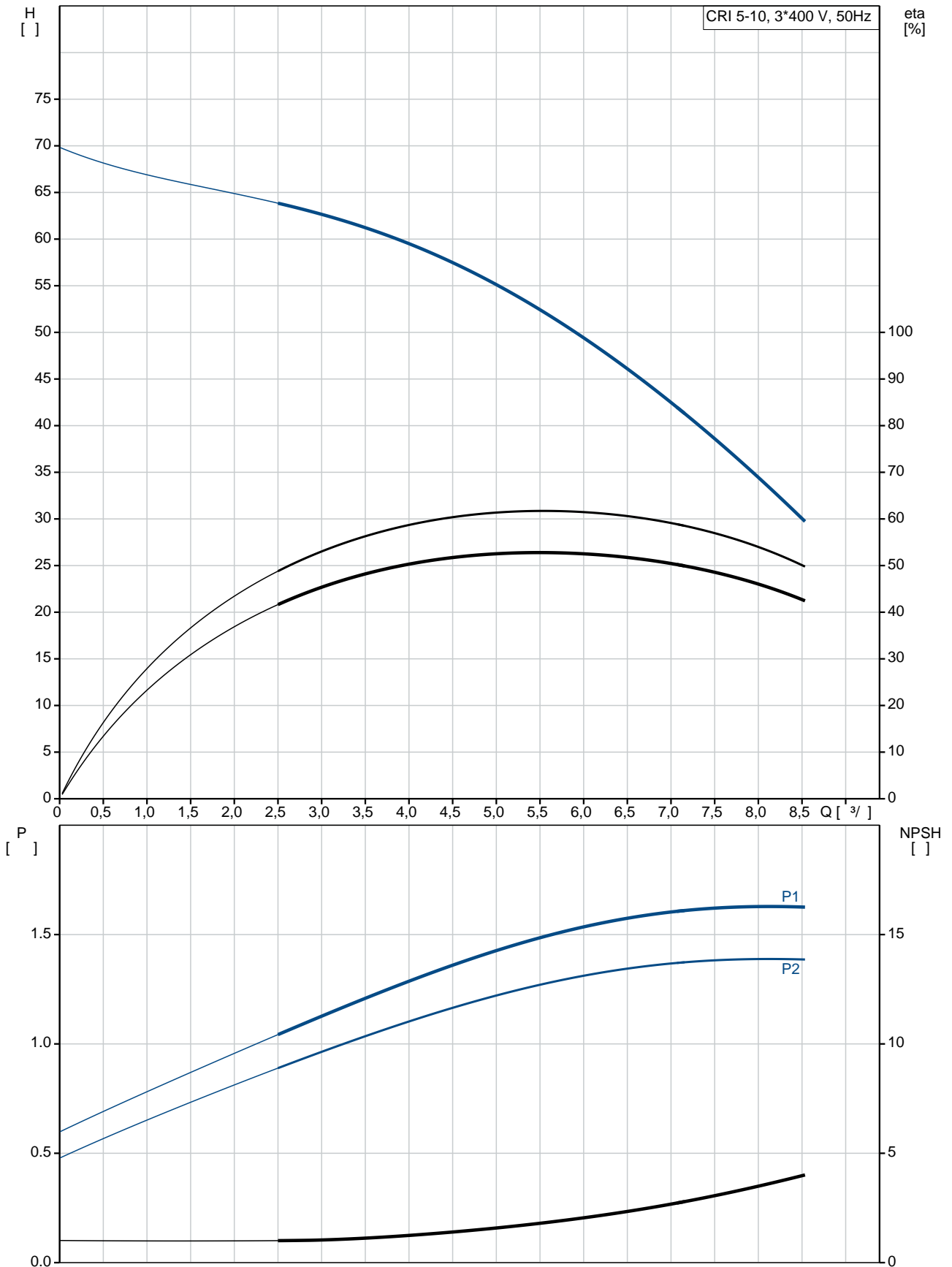

	CRI 5-10
	A-CA-A-E-HQQE
	<a href="#">96517105</a>
EAN	5700396756288
	2896 /
	5.8 <sup>3/</sup>
	51.8
	69.7
	10
	10
	0
Low NPSH:	N
	HQQE
	CE, EAC, ACS
	ISO9906:2012 3B
	A
	A
	EN 1.4408
	AISI 316
	EN 1.4301
	AISI 304
	A
	E
	SIC
Maximum ambient temperature:	60 °C
	25
	25 / 120 °C
	25 / -20 °C
	FlexiClamp
	DN 32
	DN 32
	PN 25
	FT115
	CA
	-20 .. 120 °C
	20 °C
	998.2 / <sup>3</sup>
	IEC
	90SD
	IE3
	1.5
	- P2: 1.5
( 2),	1.5

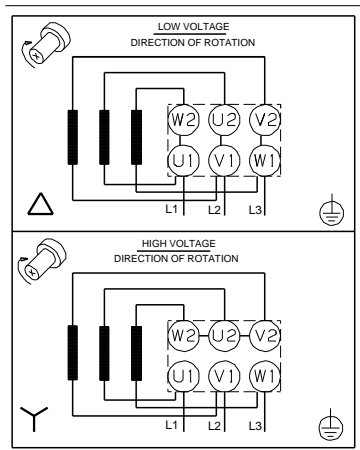
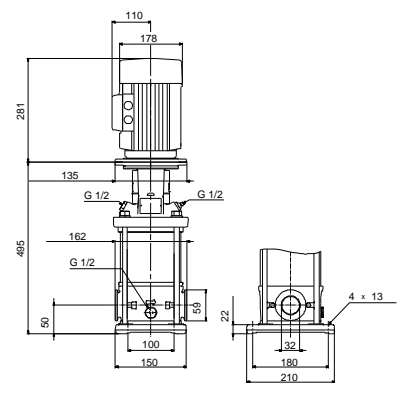
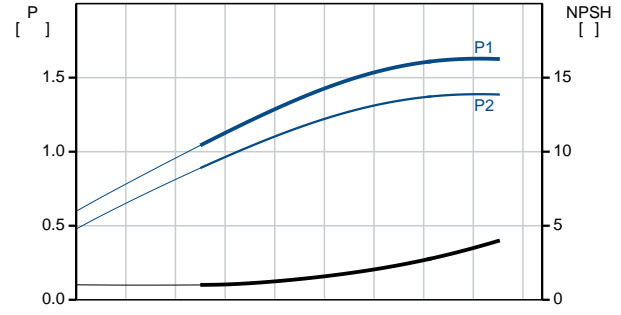
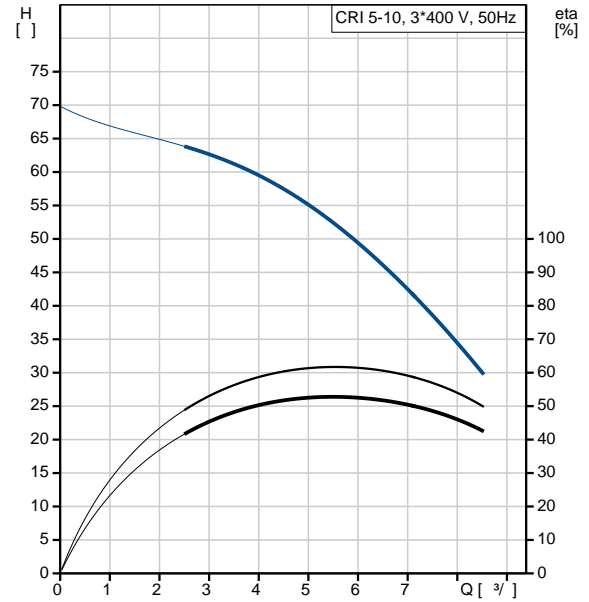

	:	50 Hz
	:	3 x 220-240D/380-415Y
	:	5.70/3.30 A
	:	750-820 %
Cos	-	: 0.84-0.78
	:	2890-2910 /
	:	IE3 84,2%
	:	84.2-84.2 %
	:	3/4 86.4 %
1/2	:	86.0 %
	:	2
	:	(IEC 34-5): 55 Dust/Jetting
	:	(IEC 85): F
	:	.
	:	85U01906
	:	.
	:	.
MEI	:	' 0.57
( )	:	32.1
( )	:	36.2
	:	0.092 <sup>3</sup>

## 96517105 CRI 5-10 A-CA-A-E-HQQE 50

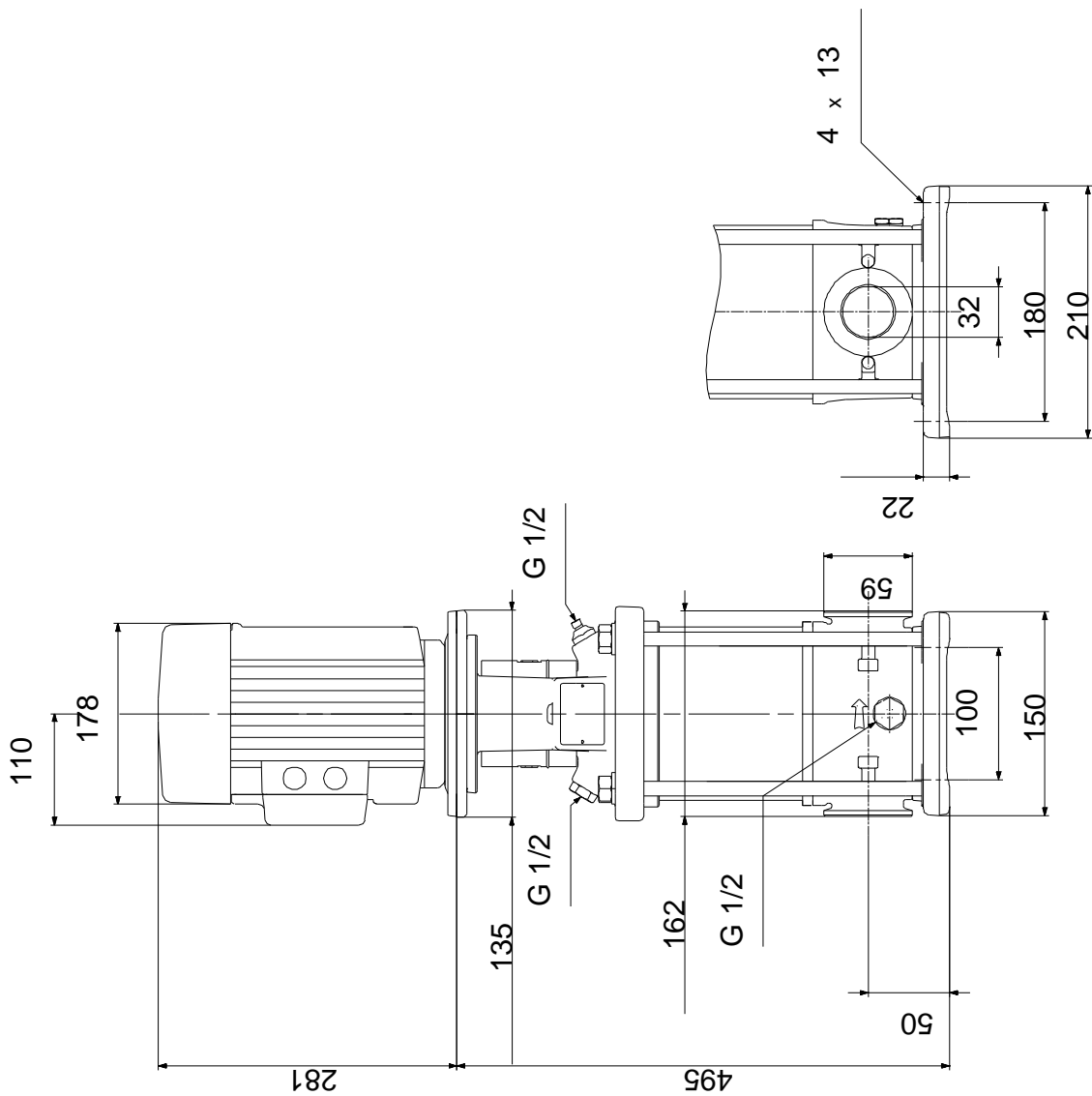

**96517105 CRI 5-10 A-CA-A-E-HQQE 50**

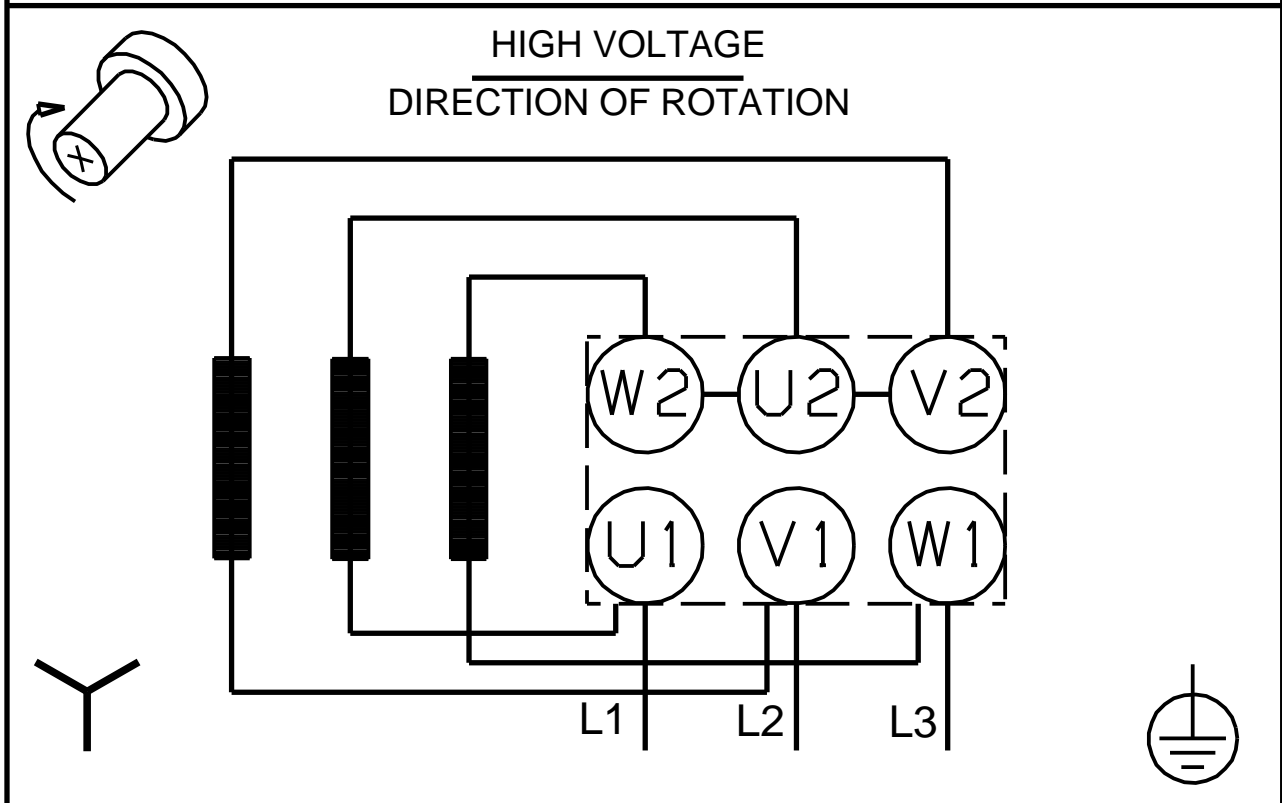
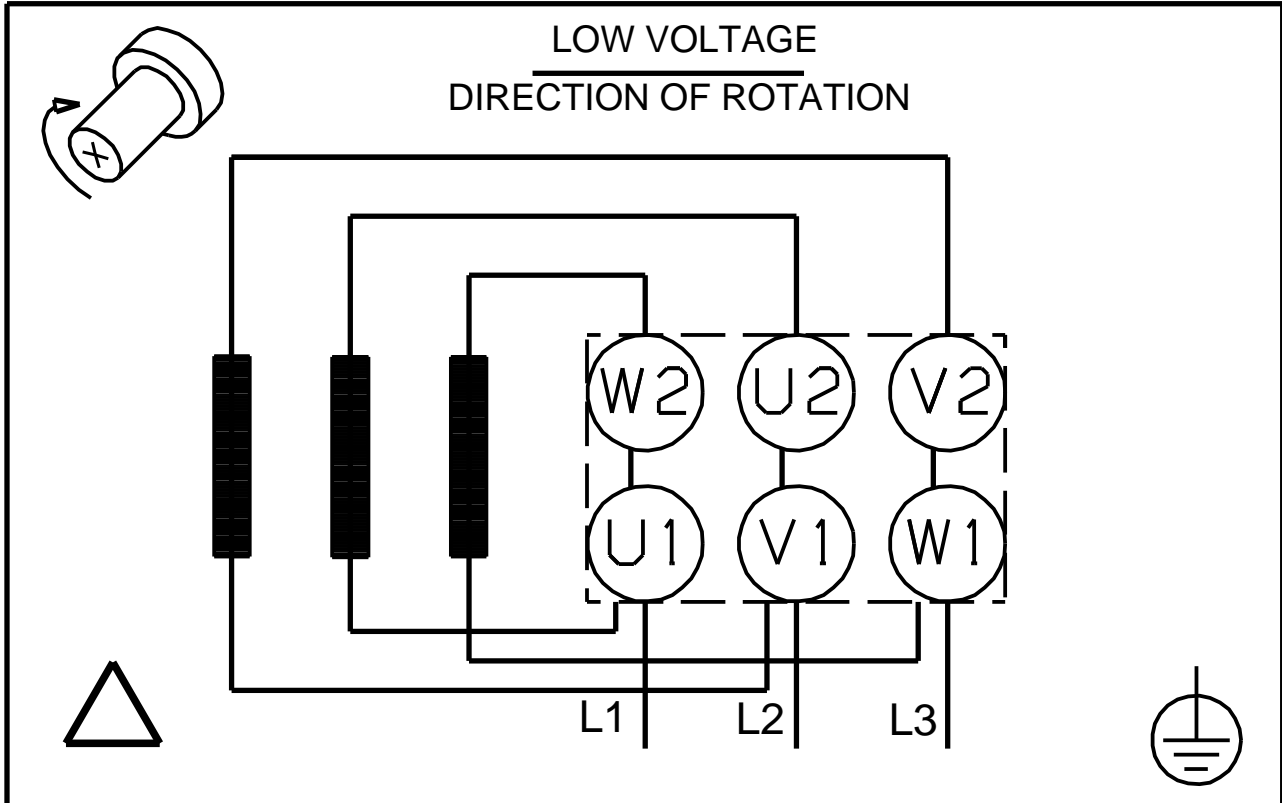

! [ ], .