

1 TPD 65-90/4 A-F-A-BQQE-FX3



: 96087477

7005-2).

EN 12756. Pipework connection is via PN 16 DIN flanges (EN 1092-2 and ISO

Frequency converter:

: -25 .. 120 °C
 : 20 °C
 : 998.2 / ³

: 1400 /

: 23 ³/_l
 : 7.18
 : 162
 : BQQE
 - : ISO9906:2012 3B2

c : EN-GJL-250
 : ASTM class 35
 : EN/DIN: EN-GJL-200
 : AISI/ASTM: ASTM class 30

: -30 .. 60 °C

: 16
 - : 16 / 120 °C
 : DIN
 : DN 65

: PN 16
 : 360
 : FF165
 :
 : 90SC
 - : IE3
 - P2: 0.75
 : 50 Hz
 : 3 x 220-240D/380-415Y
 : 3.60/2.10 A
 : 620-670 %
 Cos - : 0.71-0.64
 : 1455-1463 /
 : IE3 82,5%
 : 82.5 %
 3/4 : 83.6 %
 1/2 : 81.1 %
 : 4
 (IEC 34-5): 55 Dust/Jetting
 (IEC 85): F
 : 87120313
 :
 , MEI : 0.70
 (): 112
 (): 126
 : 0.38 ³
 C : HU
 : 8413705100

96087477 TPD 65-90/4 A-F-A-BQQE-FX3 50

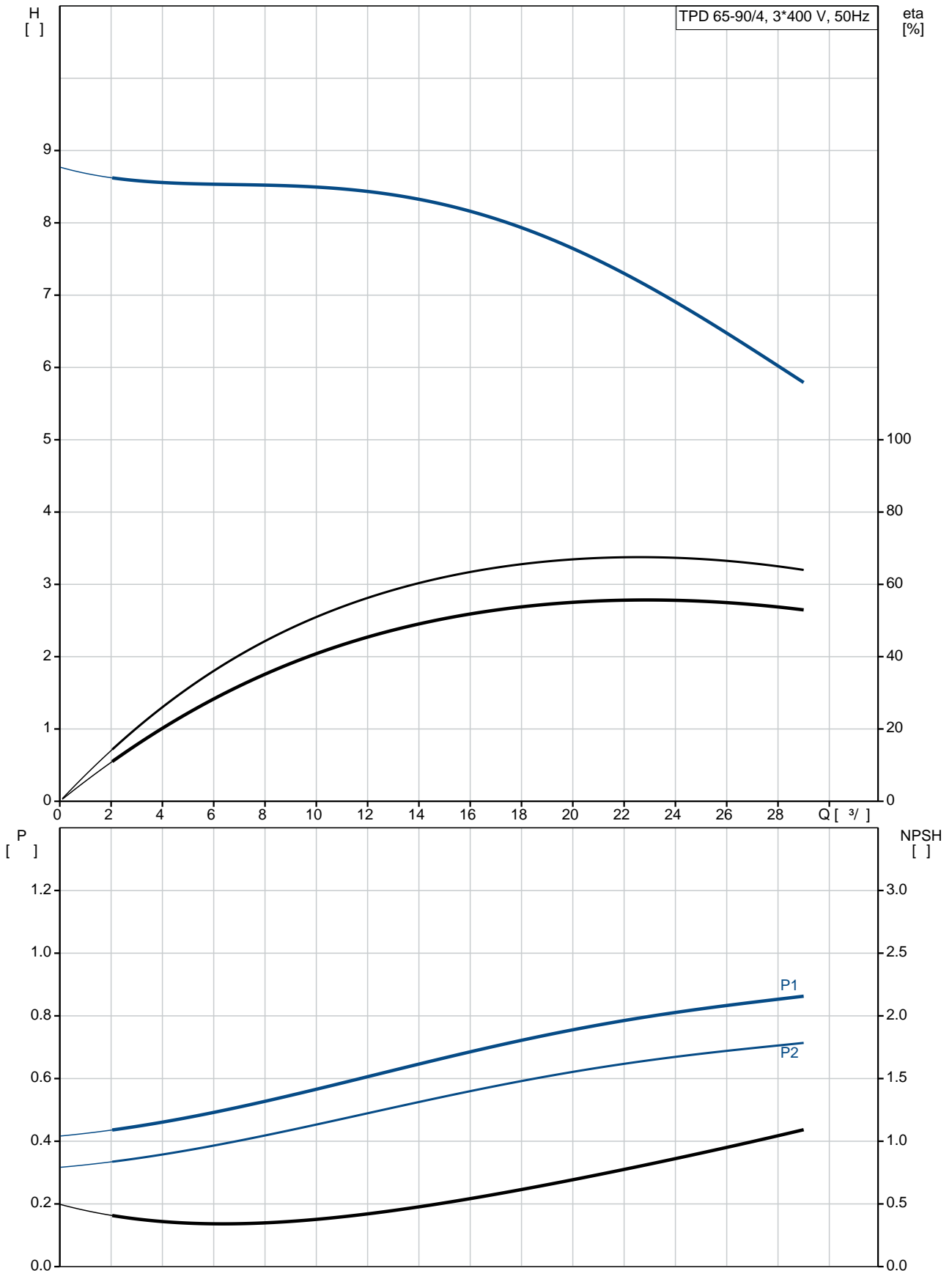

TPD 65-90/4	A-F-A-BQQE-FX3
EAN	5700395314434
	1400 /
	23 ^{3/}
	7.18
	90
	162
	BQQE
	ISO9906:2012 3B2
	A
c	EN-GJL-250
	ASTM class 35
	EN/DIN: EN-GJL-200
	AISI/ASTM: ASTM class 30
	A
	-30 .. 60 °C
	16
	16 / 120 °C
	DIN
	DN 65
	PN 16
	360
	FF165
	F
	-25 .. 120 °C
	20 °C
	998.2 / ³
	90SC
	IE3
- P2:	0.75
	50 Hz
	3 x 220-240D/380-415Y
	3.60/2.10 A
	620-670 %
Cos	0.71-0.64
	1455-1463 /
	IE3 82,5%
	82.5 %
	3/4 83.6 %
1/2	81.1 %
	4
(IEC 34-5):	55 Dust/Jetting

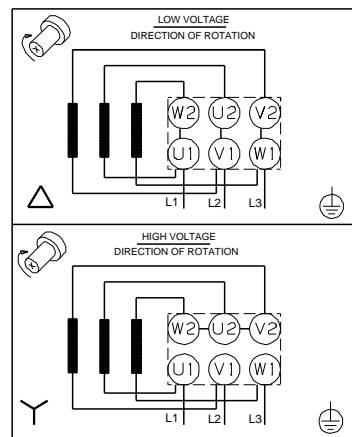
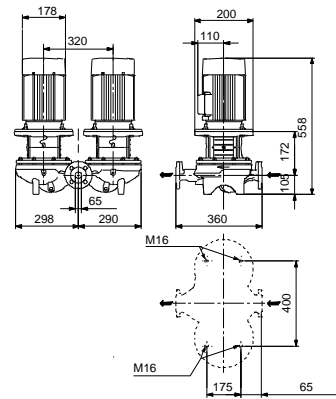
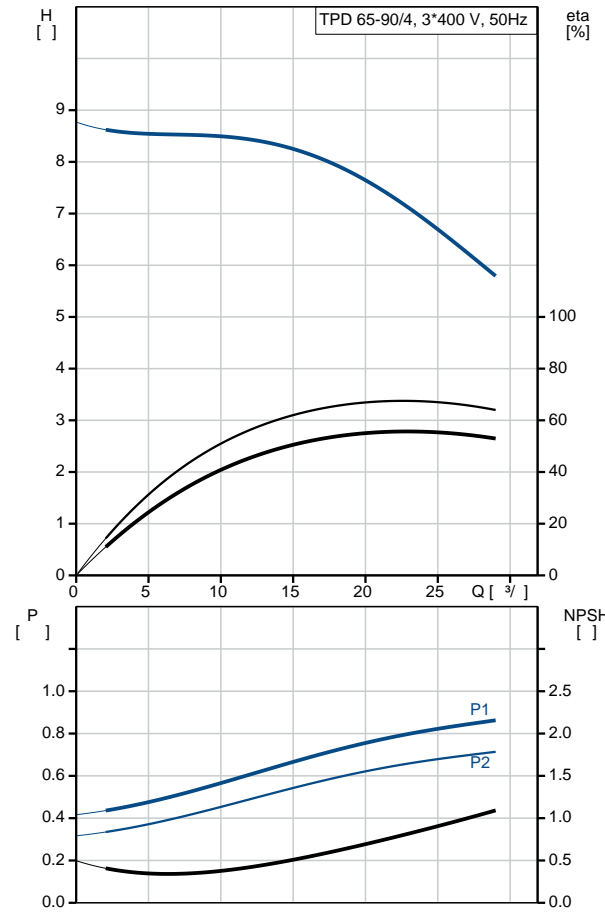

(IEC 85):	F
:	:
:	87120313
:	:
:	:
:	:
, MEI :	0.70
():	112
():	126
:	0.38 ³
C :	HU
:	8413705100

96087477 TPD 65-90/4 A-F-A-BQQE-FX3 50

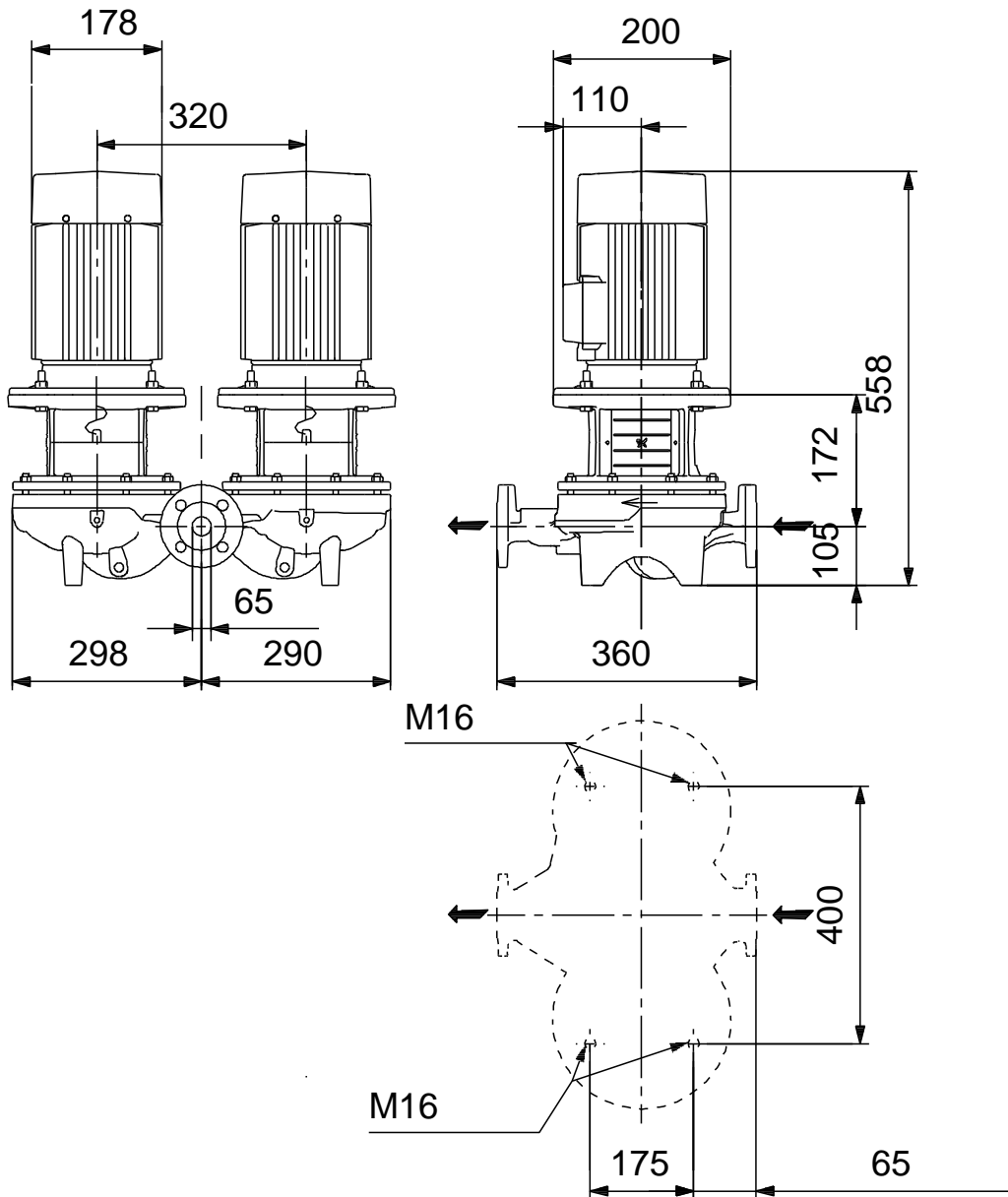

96087477 TPD 65-90/4 A-F-A-BQQE-FX3 50

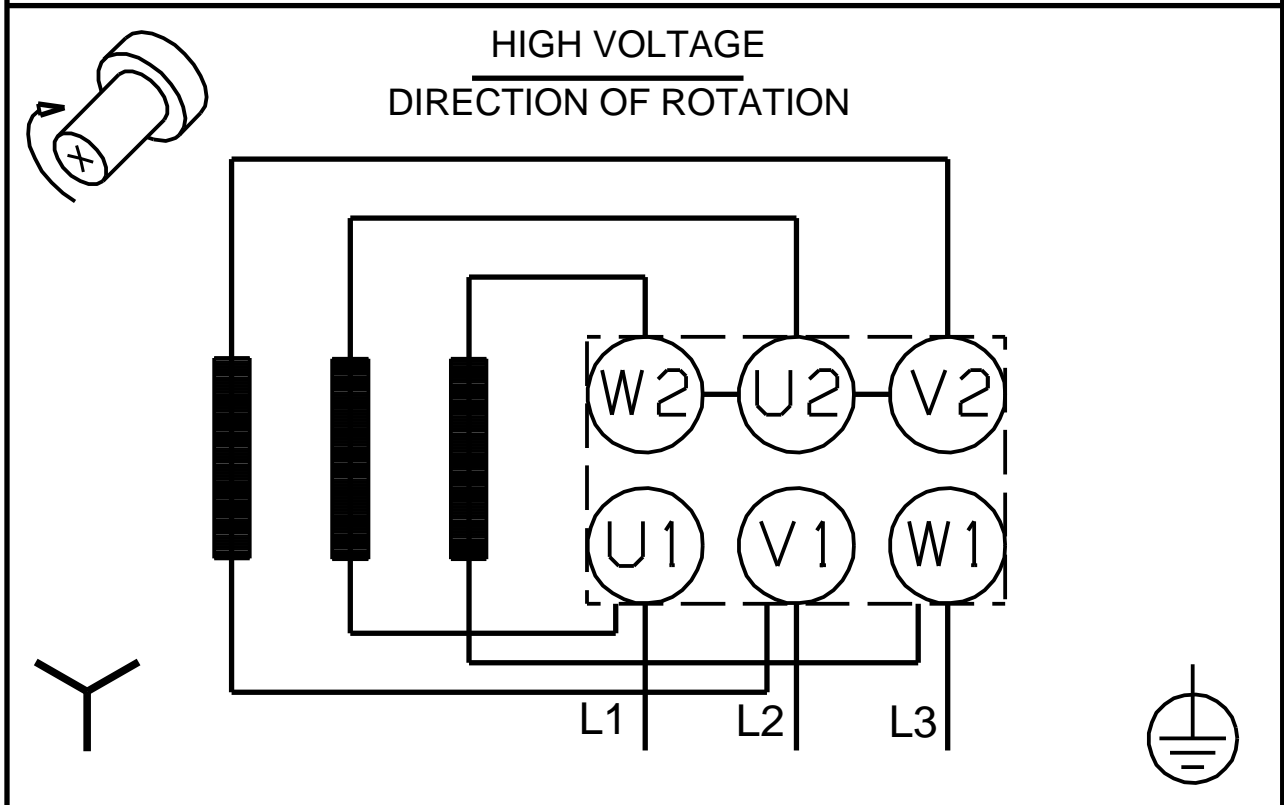
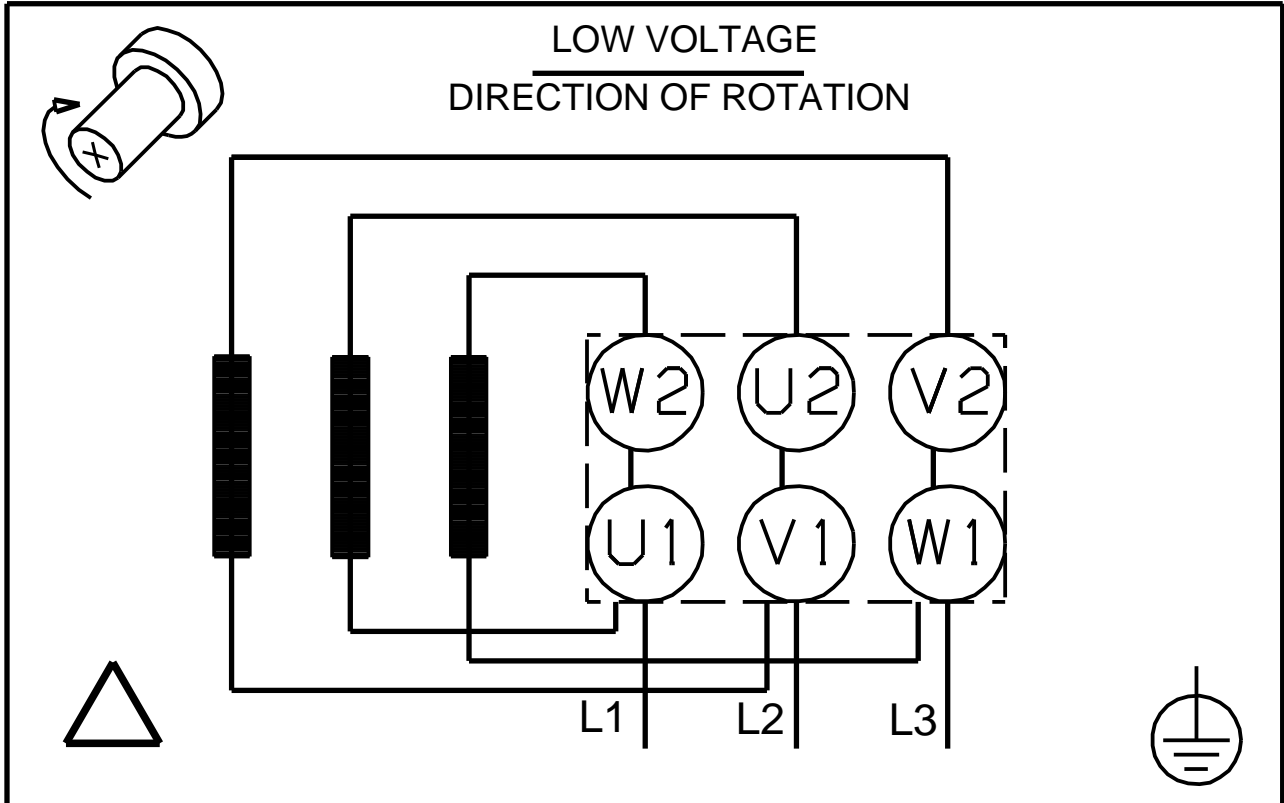

! [], .